

Frequency Conversion Component

RF:27-31.5GHz/IF:950-2450MHz/Gain:50dB

Model: TLLNB27G31.5G-50-3

The TLLNB27G31.5G-50-3 is a frequency conversion component operating in the Ka-band. It features an integrated local oscillator, with input RF frequency of 27~31.5 GHz and output IF frequency of 950~2450 MHz. Providing a conversion gain of 50 dB, it also supports adaptive switching between internal and external references.

Features:

- RF Frequency range: 27-31.5GHz
- IF Frequency range: 950-2450MHz
- Gain: 50dB
- External/Internal Reference Adaptive

Applications:

- Test Lab
- Instrumentations
- Auto Test Set

Electrical Characteristics:

Parameter	Value	Units	Description
RF Input Frequency	27-28.5	GHz	26.05GHz@LO
	28-29.5		27.05GHz@LO
	29-30.5		28.05GHz@LO
	30-31.5		29.05GHz@LO
IF Output Frequency	950-2450	MHz	
Gain	≥50	dB	
Gain Control Step	0.5	dB	Maximum Attenuation Range of 31.5 dB
Flatness	≤±2	dB	
Noise Figure	≤3	dB	
Phase Noise	≤-80@1KHz	dBc/Hz	
	≤-85@10KHz		
	≤-95@100KHz		
	≤-100@1MHz		
Image Rejection	≥40	dBc	
Spurious @IF out	≥60	dBc	
Group Delay	≤±2 @100 MHz BW	ns	
Output P1dB	≥15	dBm	

Electrical Characteristics:

Parameter	Value	Units	Description
LO Reference Mode	External/Internal Reference Adaptive		External reference with fallback to Internal Reference
External LO Reference	≥5	dBm	Sine wave, 100MHz
Output Reference Clock	100	MHz	Output Level: ≥+10dBm
VSWR	≤2	:1	
DC Supply Voltage	+12	V	
Ingress Protection Grade	IP67		

Mechanical Specifications:

Parameter	Value	Description
Operating Temperature	-30~+65°C	°C
Input/Output Connector	WR28/N Female	
Remote Control Connector	M8 Female, 4 pin 1 = NC 2 = A pos+ RS485 3 = B neg- RS485 4 = Common (GND)	1、 LO Frequency Setting 2、 Digital Attenuator Setting 3、 Internal/External Reference Status Query 4、 PLL Lock Status Monitoring 5、 DC Power Supply Status Monitoring
Communication Connector	RS485	
DC supply Interface	SMA	+12 V
Reference Output Reference Interface	SMA	100MHz
External Reference Input Interface	SMA	100MHz

Note: The PLL frequency and the Digital Attenuator attenuation will be done by writing a number in the relevant register as per the communication protocol.

Outline Drawing:

Unit:mm

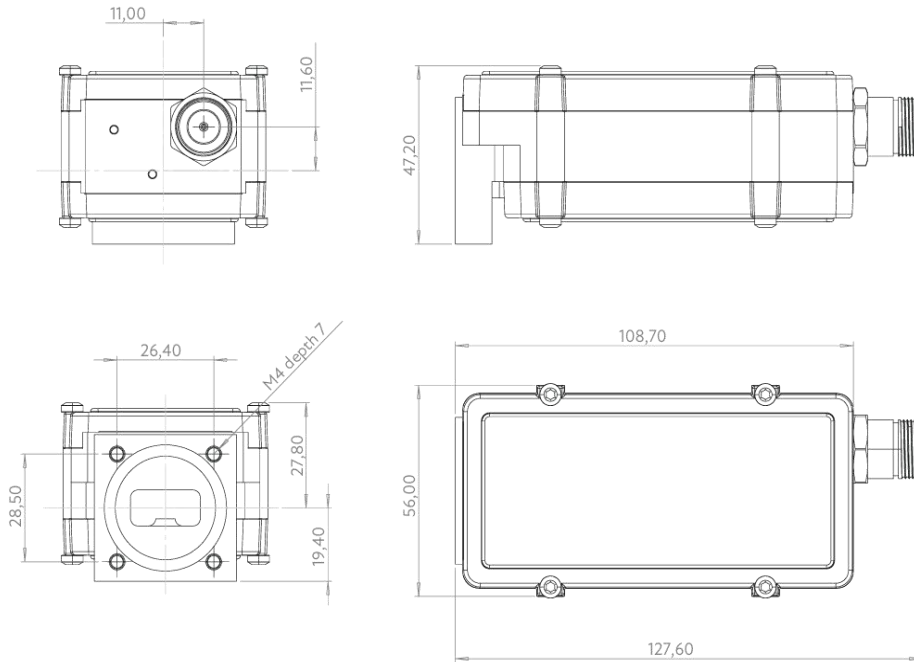

Notes:

The dimensions of the module is yet to be determined.

Functional Block Diagram:

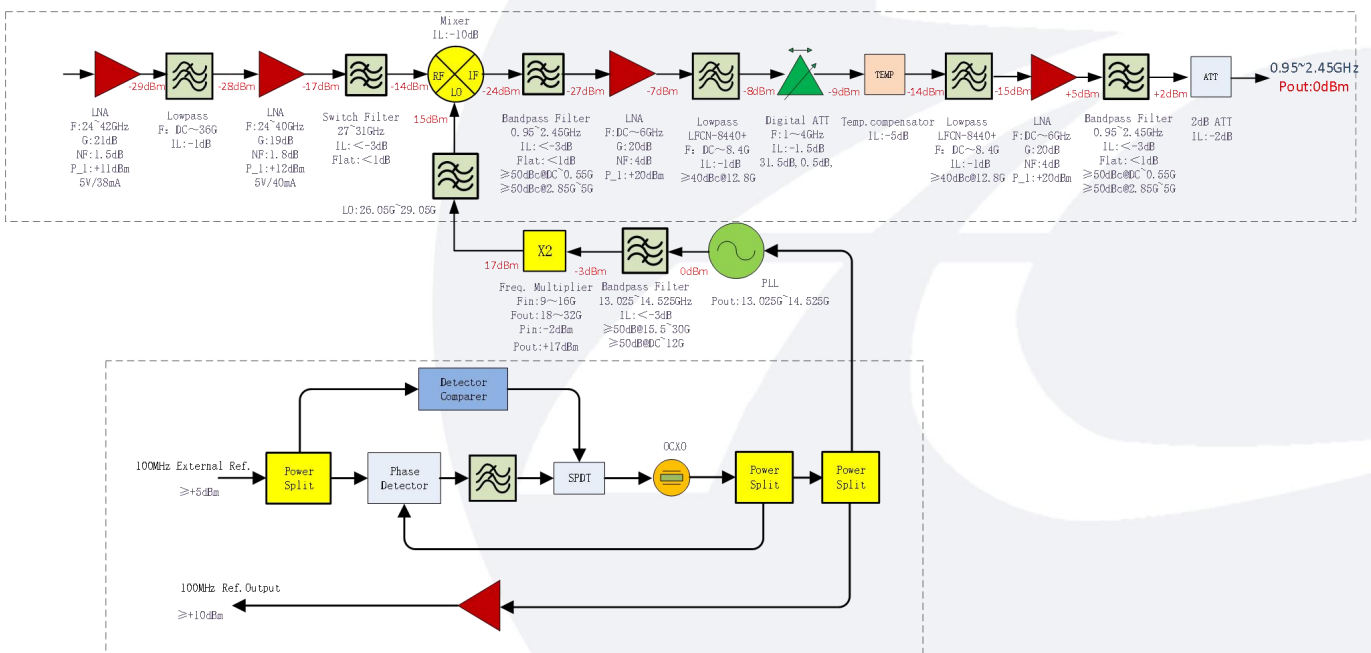

Ordering Information:

Base Number	Description	Revision
TLLNB27G31.5G-50-3	Frequency Conversion Component, RF frequency; 27~31.5 GHz, Gain: 50dB	Rev.1.2

Notes:

1. Dimensions and specifications may be changed without prior notice.
2. Standard Warranty: three years.

Typical Performance Data:

Input VSWR vs Frequency

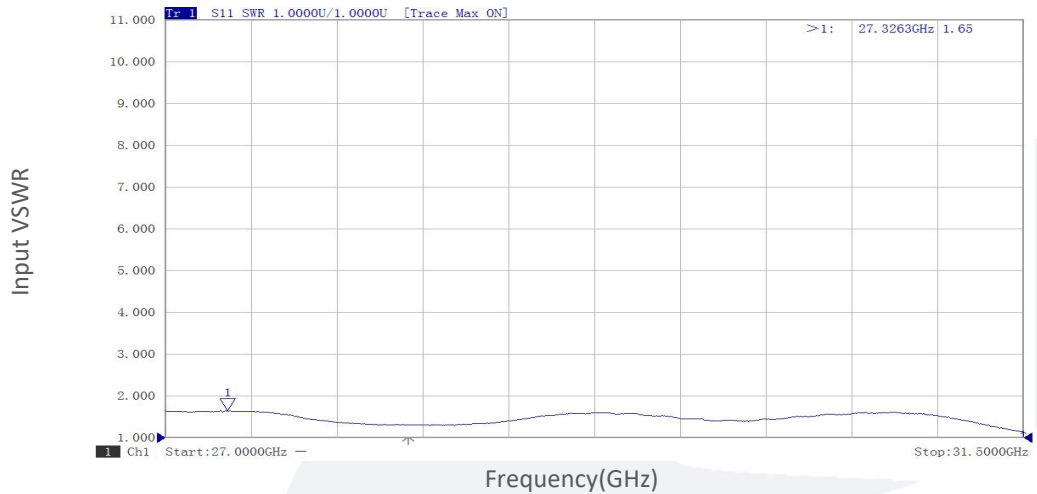

Output VSWR vs Frequency

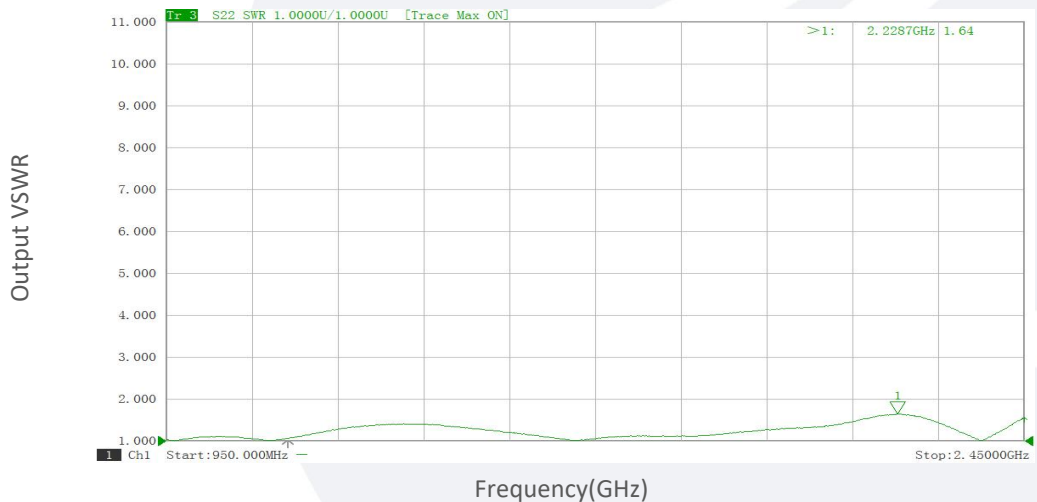

Note: Above data is for ref only, actual data may vary from unit to unit depending on operating environment and other factors like material lots etc.

Typical Performance Data:

Pout Flatness vs Frequency@RF Pin=-50dBm,27~28.5GHz

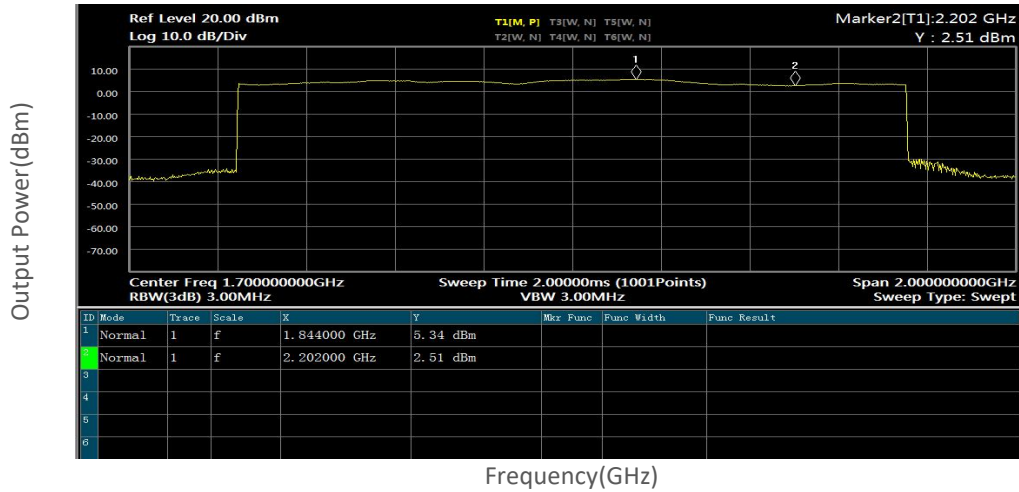

Pout Flatness vs Frequency@RF Pin=-50dBm,28~29.5GHz

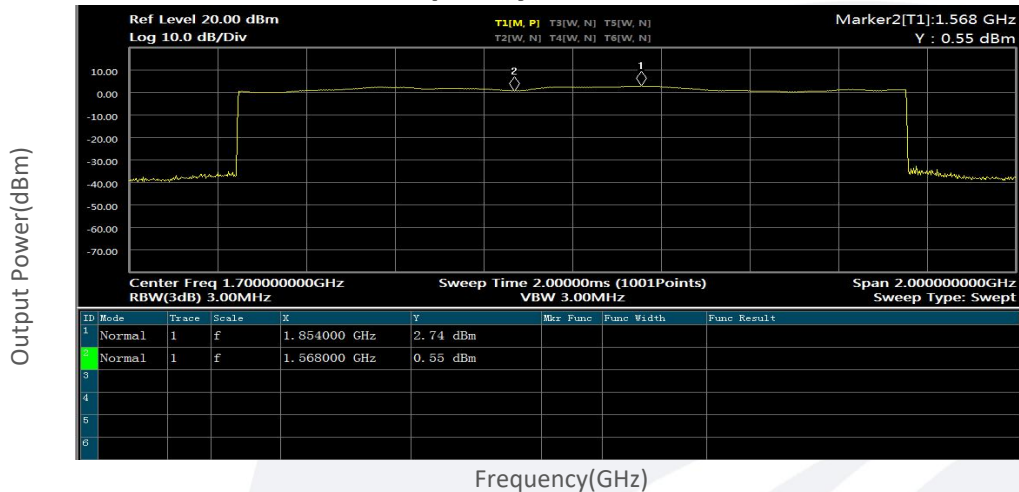

Pout Flatness vs Frequency@RF Pin=-50dBm,29~30.5GHz

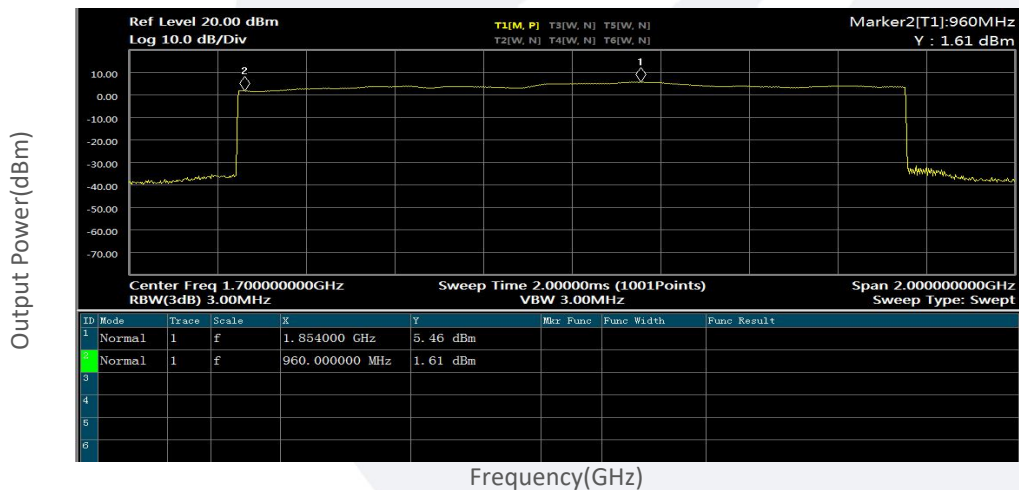

Note: Above data is for ref only, actual data may vary from unit to unit depending on operating environment and other factors like material lots etc.

Typical Performance Data:

Pout Flatness vs Frequency@RF Pin=-50dBm,30~31.5GHz

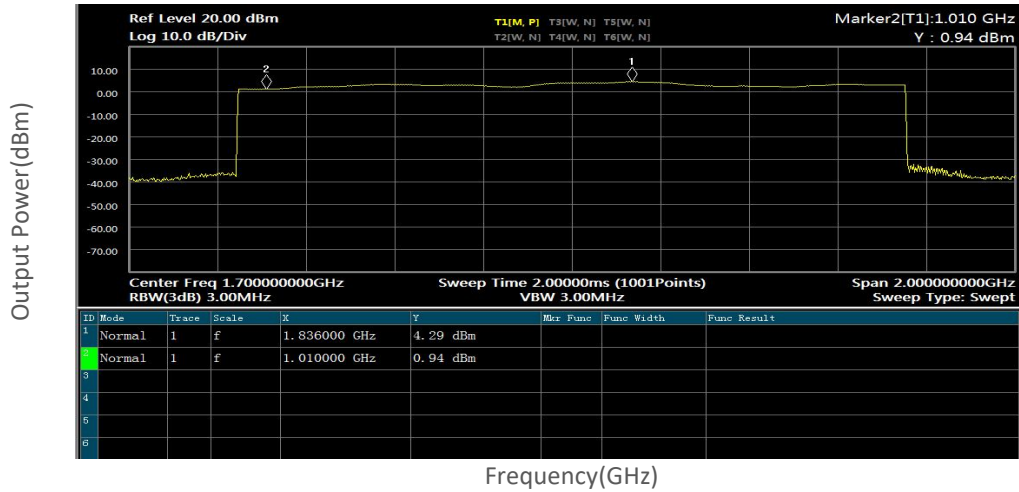

Noise Figure vs Frequency

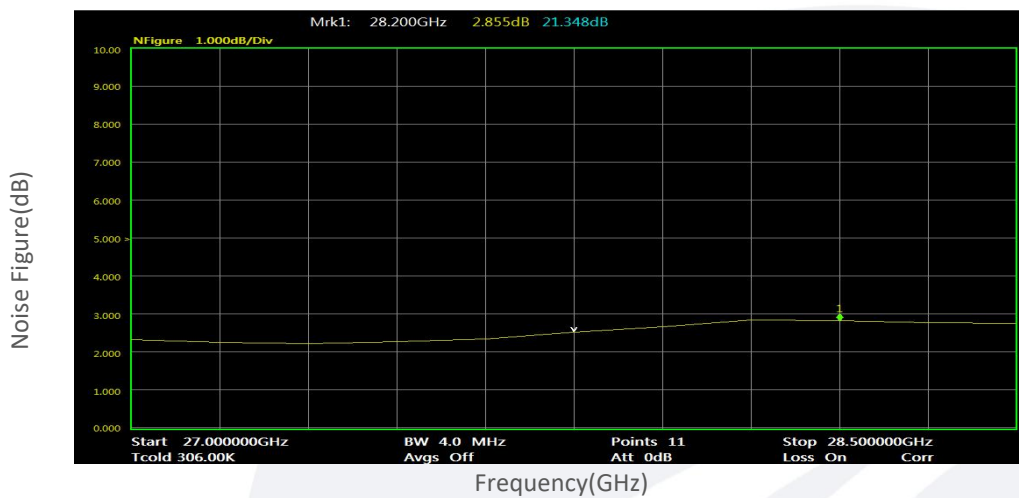

Noise Figure vs Frequency

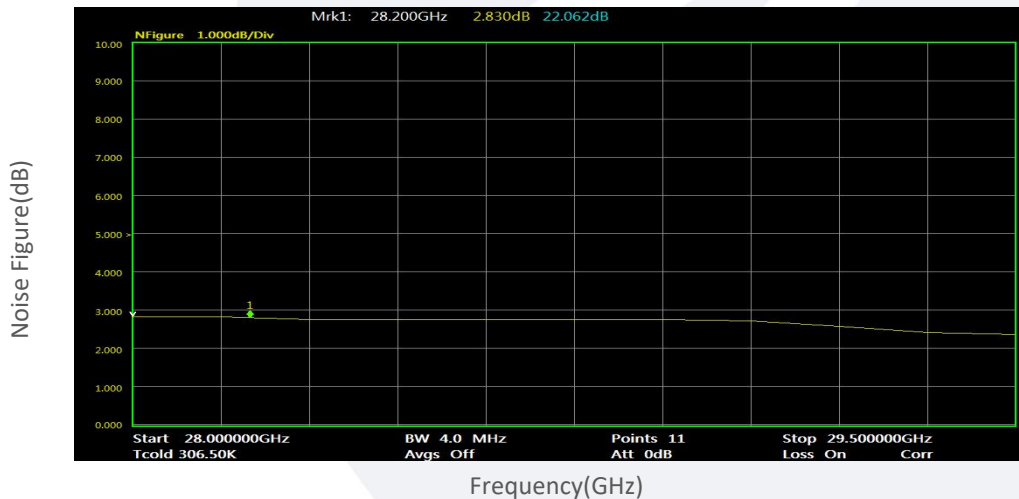

Note: Above data is for ref only, actual data may vary from unit to unit depending on operating environment and other factors like material lots etc.

Typical Performance Data:

Noise Figure vs Frequency

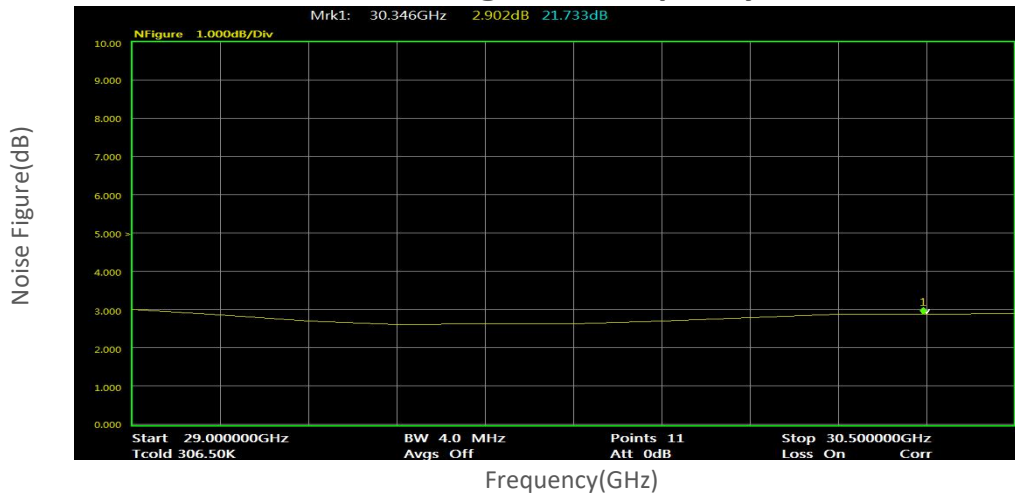

Noise Figure vs Frequency

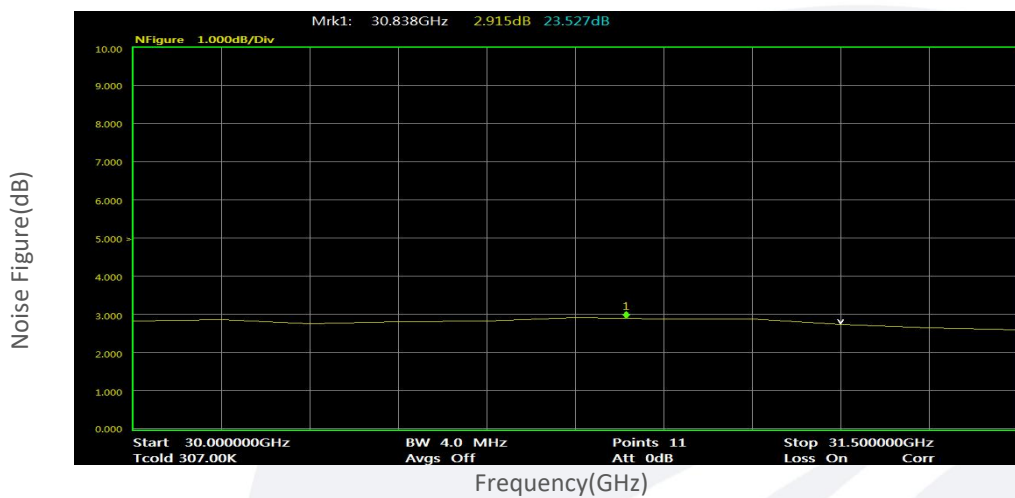

Phase Noise @950MHz

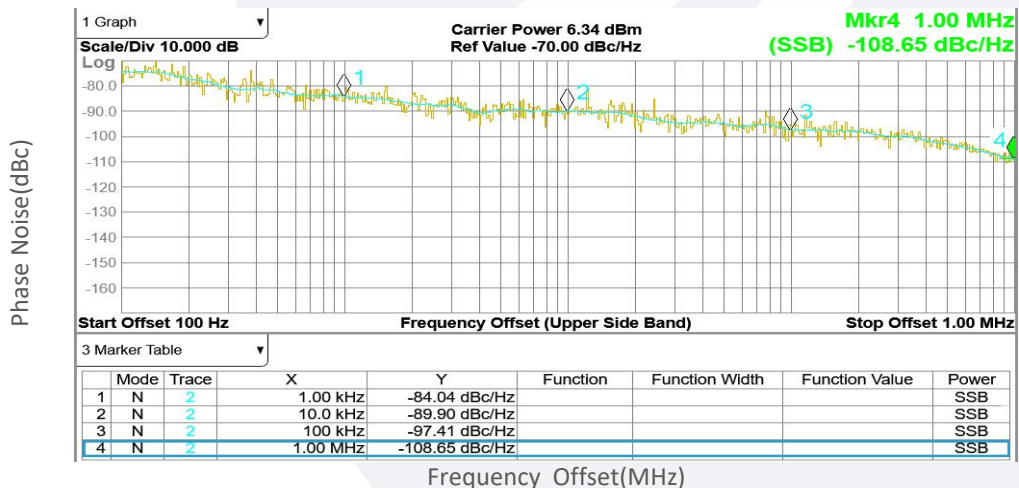

Note: Above data is for ref only, actual data may vary from unit to unit depending on operating environment and other factors like material lots etc.

Typical Performance Data:

Phase Noise @1700MHz

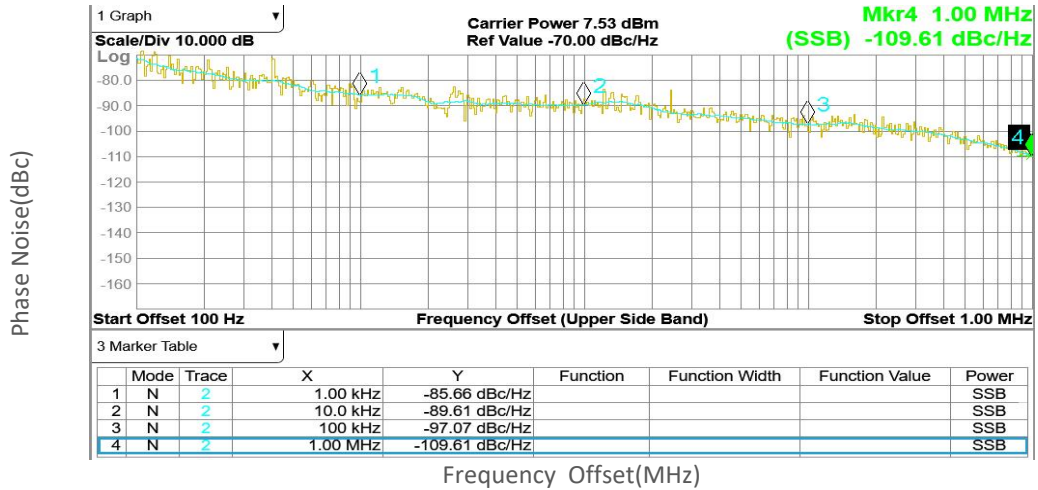

Phase Noise @2450MHz

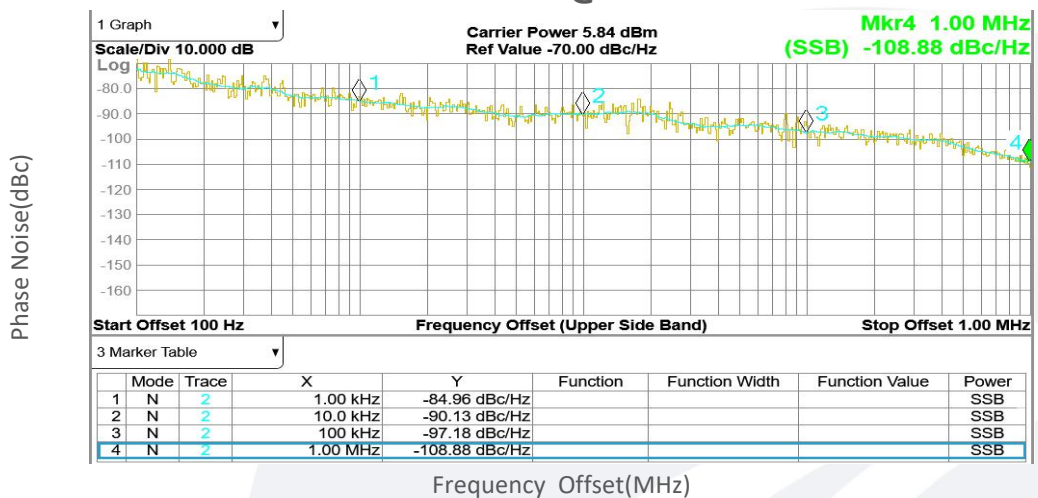

Near-end Spurious@1700MHz

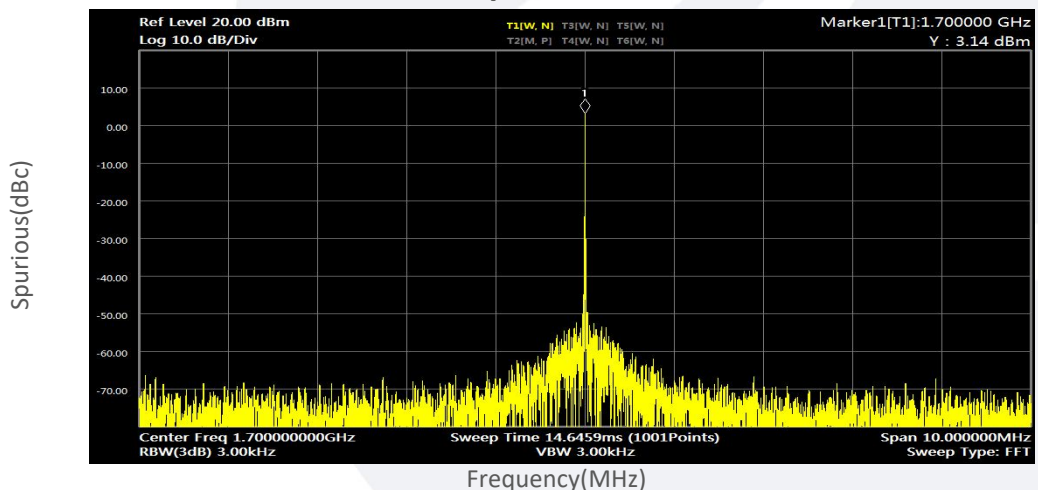

Note: Above data is for ref only, actual data may vary from unit to unit depending on operating environment and other factors like material lots etc.

Typical Performance Data:

Far-end Spurious vs Frequency@1700MHz

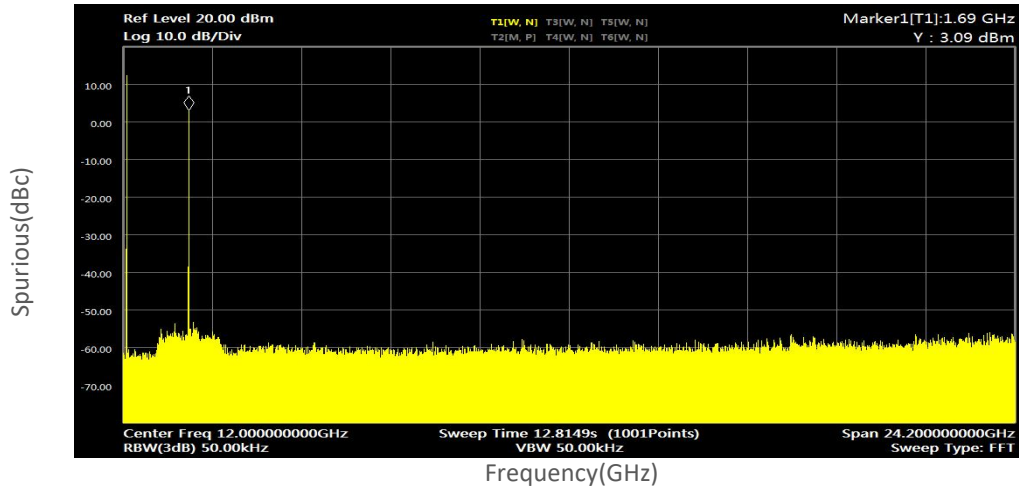

RF Pin:-50dBm@24.35GHz
LO Frequency=26.05GHz

Image Rejection@27.75GHz

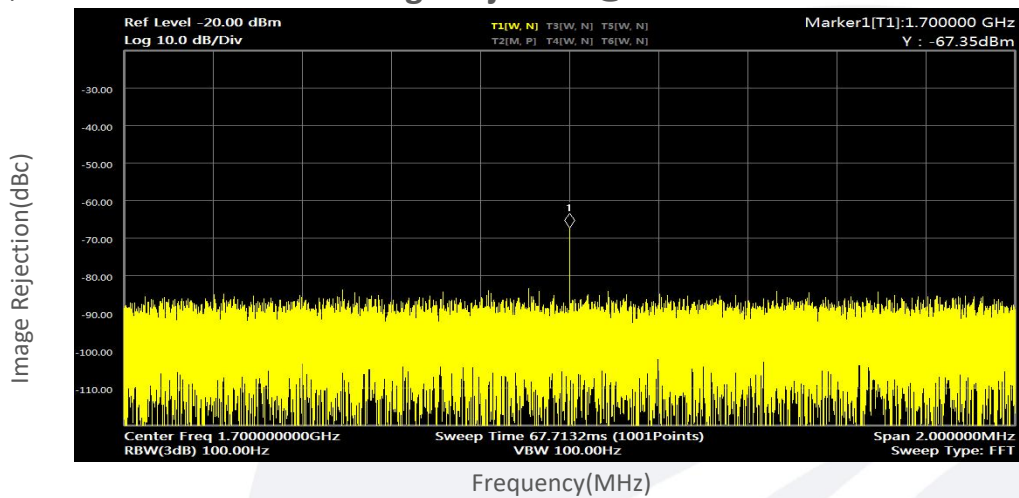

Output Power@Output Reference Clock

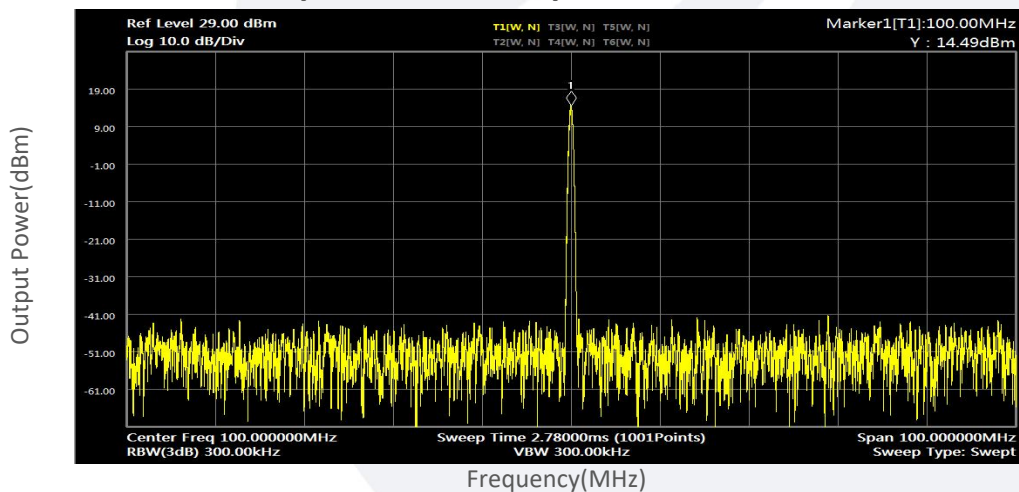

Note: Above data is for ref only, actual data may vary from unit to unit depending on operating environment and other factors like material lots etc.